

## APPLICATIONS

The SQUARE-PLEX™ compact fluorescent luminaire series 540 offered in three sizes, utilizes energy efficient Circline, Twin Tube, Quad Tube, 2D and Biax lamps providing high light output combined with clean unobtrusive design. For wall or ceiling mounting.

For Corridors, Stair Wells, Bathrooms and Kitchens, in Public Buildings, Schools, Hotels, Hospitals and Residences.

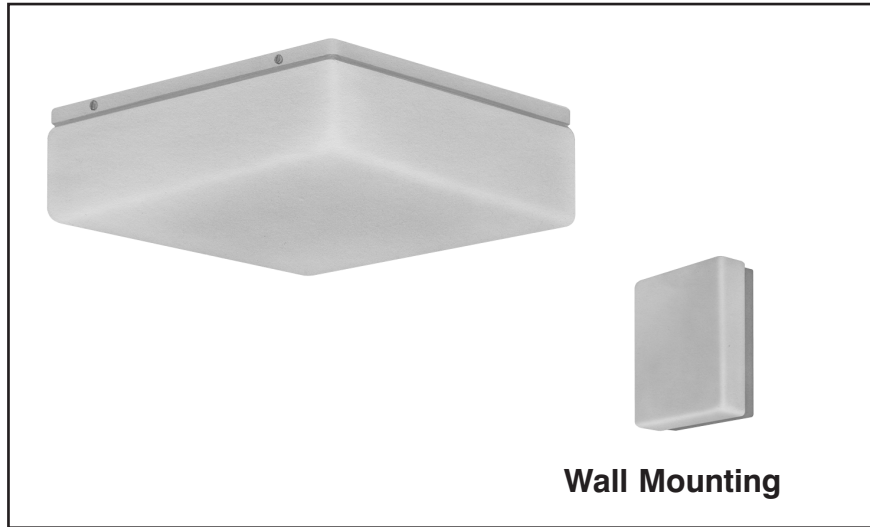

## SPECIFICATIONS

**CONSTRUCTION:** Formed of heavy gauge cold rolled steel.

**SHIELDING:** Molded, one piece of cast white acrylic material, retained to housing by screws, easily removable for relamping. Optionally available in white polycarbonate high impact plastic with tamper proof screws (see Options listing).

**MOUNTING:** By means of keyhole slots to outlet box, with hole for center lock-up, provided with bushed hole for wire feed. Can be mounted on wall or ceiling.

**BALLAST:** Single and/or Two lamp ballast for Circline, Twin Tube and 2D lamps, for 118 volt 60 Hz operation, class "P", (consult factory for other voltages and frequencies).

**FINISH:** All steel component parts are completely protected against rust and discoloration by an Anchored Process and coated with 365° baked white synthetic enamel for maximum durability, providing a high reflectance efficiency. Available in BLACK finish (see Options listing).

**CERTIFICATION:** The Square-Plex™ Series 540 luminaire is U.L. and C.U.L. listed and bears the label of the I.B.E.W./AFL-CIO, Local #3.

SQUARE-PLEX™ is a trademark of LEGION LIGHTING CO., INC.  
LEGION® is a registered trademark of LEGION LIGHTING CO., INC.

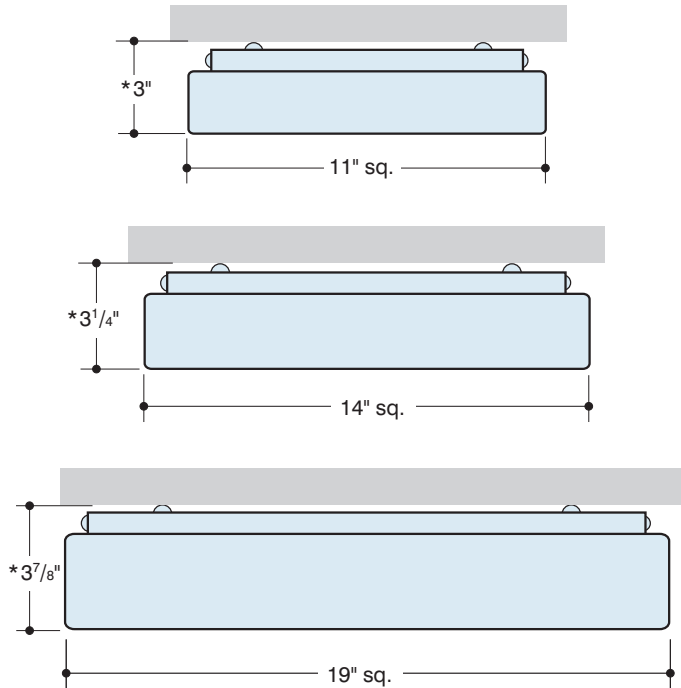

\* Extension collar is required whenever using Quad lamps and certain Emergency Packs which will increase the overall height of the fixture by 1 1/2".



**ORDERING DATA**

Catalog No.	No. and Type Lamps	Socket Base	Nom. Dims.		Wt.
			Depth	Dia.	
540-11-22C-ACW	1-22W/FC8T9	G10q	3"	11" sq.	6
540-11-1F7TTC- ACW	1-7W/5T4/Twin	G23	3"	11" sq.	6
540-11-2F7TTC-ACW	2-7W/5T4/Twin	G23	3"	11" sq.	7
540-11-1F9TTC-ACW	1-9W/6T4/Twin	G23	3"	11" sq.	7
540-11-2F9TTC-ACW	2-9W/6T4/Twin	G23	3"	11" sq.	8
540-11-1F13TTC-ACW	1-13W/7T4/Twin	GX23	3"	11" sq.	7
540-11-2F13TTC-ACW	2-13W/7T4/Twin	GX23	3"	11" sq.	8
540-11-3F13TTC-ACW	3-13W/7T4/Twin	GX23	3"	11" sq.	8

Since lamp technology is ever changing, consult factory for lamping configurations and types other than shown.

NOTE: Quad lamps available, extension collar required, CONSULT FACTORY

**ORDERING DATA**

Catalog No.	No. and Type Lamps	Socket Base	Nom. Dims.		Wt.
			Depth	Dia.	
540-14-32C-ACW	1-32W/FC12T9	G10q	3¼"	14" sq.	7
540-14-54C- ACW	1-32W/FC12T9 1-22W/FC8T9	G10q	3¼"	14" sq.	8
540-14-2F13TTC-ACW	2-13W/7T4/Twin	GX23	3¼"	14" sq.	9
540-14-3F13TTC-ACW	3-13W/7T4/Twin	GX23	3¼"	14" sq.	10
540-14-4F13TTC-ACW	4-13W/7T4/Twin	GX23	3¼"	14" sq.	11
● 540-14-2F18TTC-ACW	2-18W/10T5/Twin	2G11	3¼"	14" sq.	11
● 540-14-1F282D-ACW	3-28W/8/2D	GR10q-4	3¼"	14" sq.	8

- Electronic "HPF" Ballast for 4-pin lamps supplied in all 18W and 2D Units. Consult factory for availability of electronic ballasts for other units.

Since lamp technology is ever changing, consult factory for lamping configurations and types other than shown.

NOTE: Quad lamps available, extension collar required, CONSULT FACTORY

**ORDERING DATA**

Catalog No.	No. and Type Lamps	Socket Base	Nom. Dims.		Wt.
			Depth	Dia.	
540-19-40C-ACW	1-40W/FC16T9	G10q	3 <sup>7</sup> / <sub>8</sub> "	19" sq.	9
540-19-72C- ACW	1-32W/FC12T9 1-40W/FC16T9	G10q	3 <sup>7</sup> / <sub>8</sub> "	19" sq.	10
● 540-19-2F18TTC-ACW	2-18W/10T5/Twin	2G11	3 <sup>7</sup> / <sub>8</sub> "	19" sq.	11
● 540-19-2F27TTC-ACW	1-27W/12T5/Twin	2G11	3 <sup>7</sup> / <sub>8</sub> "	19" sq.	11
● 540-19-1F282D-ACW	1-28W/8/2D	GR10q-4	3 <sup>7</sup> / <sub>8</sub> "	19" sq.	9
● 540-19-1F382D-ACW	1-38W/8/2D	GR10q-4	3 <sup>7</sup> / <sub>8</sub> "	19" sq.	9

- Electronic "HPF" Ballast for 4-pin lamps supplied in all 18W, 27W, and 2D Units. Consult factory for availability of electronic ballasts for other units.

Since lamp technology is ever changing, consult factory for lamping configurations and types other than shown.

NOTE: Quad lamps available, extension collar required, CONSULT FACTORY



11" SQUARE

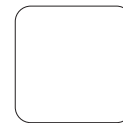

**OPTIONS**

Suffix "BLK" after cat. no. for black finish exterior housing.  
 Suffix "EXC" after cat. no. for extension collar.  
 Suffix "LT" after cat. no. for low temperature ballast (consult factory for availability).  
 Suffix "DL" after cat. no. for damp location.  
 Suffix "TP" after cat. no. for tamperproof spanner head or Torx screws. Tamperproof screw driver available.

Change suffix "ACW" to "UBW" for unbreakable vandal resistant white Smooth Polycarbonate Plastic. (Consult factory for availability and minimum quantity order).

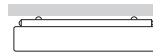

14" SQUARE



**OPTIONS**

Suffix "BLK" after cat. no. for black finish exterior housing.  
 Suffix "EXC" after cat. no. for extension collar.  
 Suffix "LT" after cat. no. for low temperature ballast (consult factory for availability).  
 Suffix "DL" after cat. no. for damp location.  
 Suffix "TP" after cat. no. for tamperproof spanner head or Torx screws. Tamperproof screw driver available.

Change suffix "ACW" to "UBW" for unbreakable vandal resistant white Smooth Polycarbonate Plastic. (Consult factory for availability and minimum quantity order).



19" SQUARE

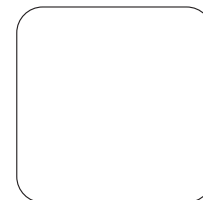

**OPTIONS**

Suffix "BLK" after cat. no. for black finish exterior housing.  
 Suffix "EXC" after cat. no. for extension collar.  
 Suffix "LT" after cat. no. for low temperature ballast (consult factory for availability).  
 Suffix "DL" after cat. no. for damp location.  
 Suffix "TP" after cat. no. for tamperproof spanner head or Torx screws. Tamperproof screw driver available.

Change suffix "ACW" to "UBW" for unbreakable vandal resistant white Smooth Polycarbonate Plastic. (Consult factory for availability and minimum quantity order).