

## APPLICATIONS

*Specifiers choice for a variety of display and utility lighting needs. Compact design occupies minimum space. Quality components, welded construction assuring long trouble free life. Broad range of types and lengths to provide the right light for the job.*



## SPECIFICATIONS

**CONSTRUCTION:** Die formed of 20 gauge cold rolled prime steel, rigidly fabricated, and electrically welded to insure true and perfect alignment.

**MOUNTING:** Installed flush with ceiling surface or stem mounted, singly or in continuous rows. For continuous mounting, end knockouts may be removed and units joined together. Adequate knockouts and holes are provided for mounting and feeds.

**ELECTRICAL:** Thermally protected Class "P" Energy Saving 265MA-T8 electronic ballasts, 430MA Rapid Start HPF, Trigger Start LPF-T12 magnetic ballasts for 118 volt 60 Hz operation standard. Other electronic ballasts, other voltages and frequencies available, consult factory. (see Options listing).

**FINISH:** All steel component parts are completely protected against rust and discoloration after fabrication through an automated conveyorized multi-stage phosphate bonding process. Finished with an electrostatic baked white polyester thermosetting powder coating. This electronic computer controlled integrated system assures consistent 88%+ reflectance efficiency and maximum durability.

**CERTIFICATION:** The Series 300 is U.L. and C.U.L. listed and bears the label of the I.B.E.W./AFL-CIO, Local #3.

Due to the very nature of coves and enclosed areas, the heat ambience temperature must be considered when designing and installing in confined spaces, so that the spaces are adequately ventilated to provide heat dissipation and air circulation to prevent ballast cycling, failure, or reduced ballast and lamp life.

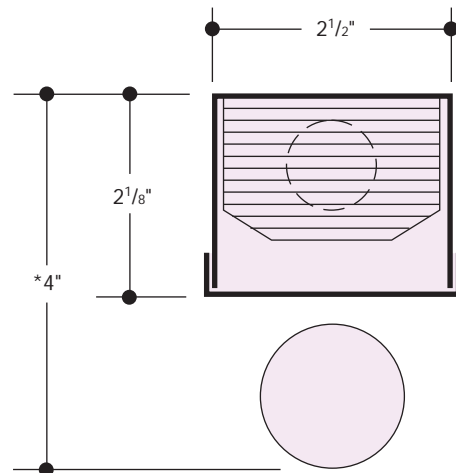

Dimensions shown are with T-12 lamp.  
\* Minus 1/4" for OCTRON T-8 lamp.

XTRALUME® and LEGION® are registered trademarks of LEGION LIGHTING CO., INC.

02/02



221 Glenmore Ave., Brooklyn, NY 11207 • Tel: 718/498-1770 • Fax: 718/498-0128  
Toll Free Fax: 800/4-LEGION

ORDERING DATA

Catalog No.	No. and Type Lamps	Nominal Dimensions	Weight
300-114	1-14W-TS-T12	2 1/2" x 15"	3
300-115	1-15W-TS-T12	2 1/2" x 18"	3
300-120	1-20W-TS-T12	2 1/2" x 24"	4
300-117 EBO	1-FO17-OCT-T8	2 1/2" x 24"	4
300-130	1-30W-RS-T12	2 1/2" x 36"	7
300-125 EBO	1-FO25-OCT-T8	2 1/2" x 36"	7
300-140	1-40W-RS-T12	2 1/2" x 48"	8
300-132 EBO	1-FO32-OCT-T8	2 1/2" x 48"	8
300-160 EBO	1-FO40-OCT-T8	2 1/2" x 60"	11
300-130-6T	2-30W-RS-T12	2 1/2" x 72"	14
300-125-6T EBO	2-FO25-OCT-T8	2 1/2" x 72"	14
300-140-8T	2-40W-RS-T12	2 1/2" x 96"	16
300-132-8T EBO	2-FO32-OCT-T8	2 1/2" x 96"	16

OPTIONS

- Suffix "DIM" after catalog no. for dimming ballast.
- Suffix "LT" after catalog no. for cold weather ballast.
- Suffix "DL" after catalog no. for damp location.
- Suffix "EM" after catalog no. for emergency battery pack, and see price list for types.
- Suffix "XTA" after catalog no. for XTRALUME® reflector standard with 85% reflectance, for 95% reflectance please specify your requirements.
- Suffix "SYM" after catalog no. for post powder coated white SYMMETRIC reflector.
- Suffix "ASYM" after catalog no. for post powder coated white ASYMMETRIC reflector.
- Suffix "ASYM1" after catalog no. for post powder coated white ASYMMETRIC reflector.
- Suffix "WG" after catalog no. for wire guard.
- Consult factory for availability of "WG" wire guard and minimum quantity order.
- Reflector available in perforated metal, add Suffix "PERF" to catalog no. i.e.: ASYM-PERF.

**ENERGY SAVING BALLASTS:** Where applicable (consult factory). Suffix "ESB" after catalog number, then / and one of the following:

**MAGNETIC**

- "SLH"- Super Low Heat T12 Ballast
- "MM-I"- Maxi Miser I T12 Ballast
- "PRE"- Premium III T12 Ballast
- "OCT"- Octron T8 Ballast
- "OPT"- Optimiser Ballast
- "DIM"- Magnetic T12 Dimming Ballast

**ELECTRONIC**

- "EB"- Electronic T12 Ballast
- "EBO"- Electronic T8 Octron Ballast
- "EBD"- Electronic T12 Dimming Ballast
- "EBDO"- Electr. T8 Octron Dimming Ballast

REFLECTOR OPTIONS

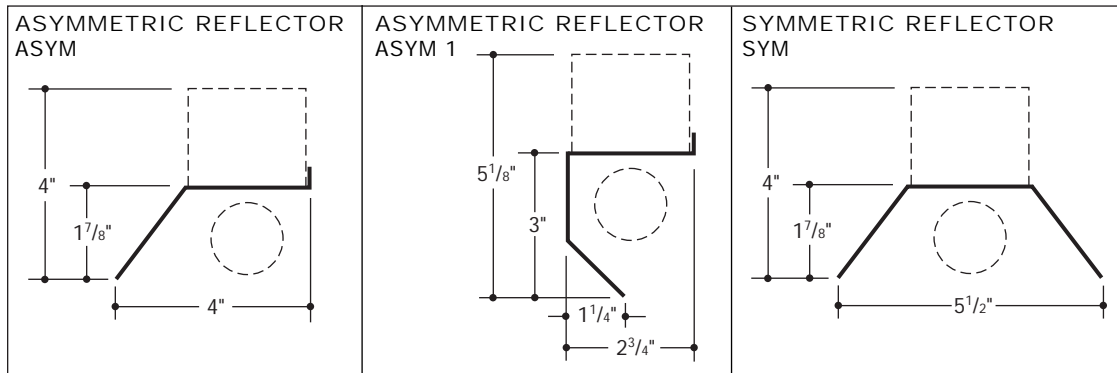

BACK PLANS

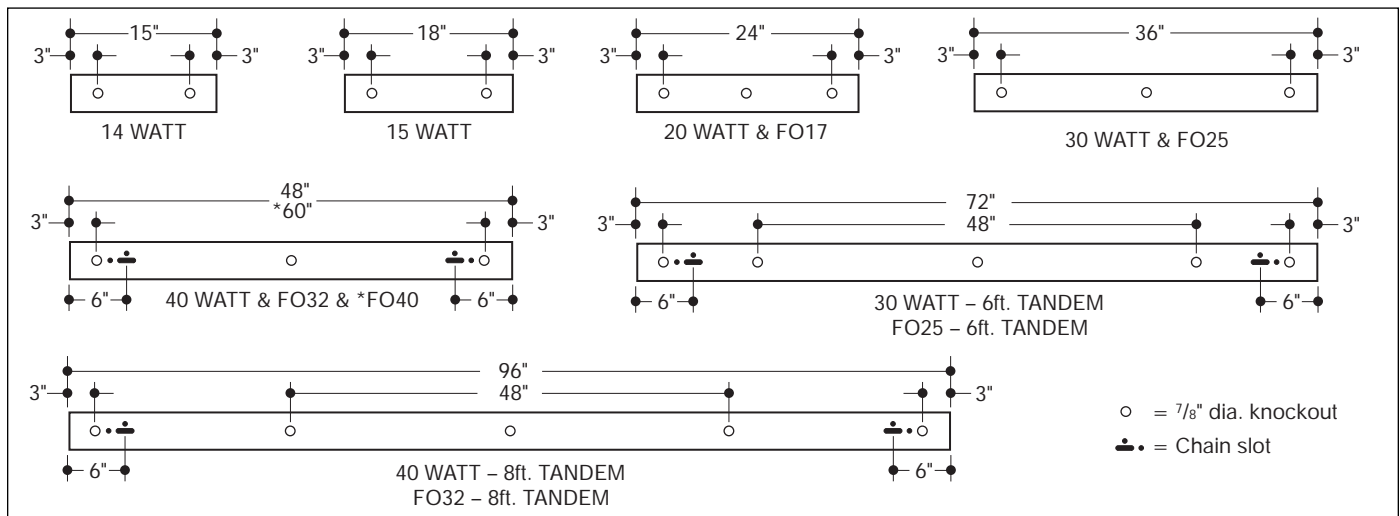

For Photometric Data consult factory. Information supplied primarily for illustrative purposes, subject to change. Consult factory for verification and minimum quantity orders.