

## APPLICATIONS

High quality multi-lamp industrial units for Octron (265MA), slimline (430MA), high output (800MA), very high output and powergroove (1500MA) lamps. Quality components, welded construction assuring long trouble free life. Engineered control for highest light output, performance and integrity. For use in industrial areas, warehouses, factories, parking garages and wherever high light output is required.



## SPECIFICATIONS

**CONSTRUCTION:** Die formed of 20 gauge cold rolled prime steel, rigidly fabricated, and electrically welded to insure true and perfect alignment.

**REFLECTOR:** Symmetrical design, code gauge steel, CAD engineered to optically correct contour, with a highly reflective post powder coated finish, provides high performance efficiency and maximum distribution of light spread. XTA-XTRALUME® energy efficient reflector available (see OPTIONS) .

**MOUNTING:** Installed flush with ceiling surface or stem mounted, singly or in continuous rows. For continuous mounting, end knockouts may be removed and units joined together. Adequate knockouts for stem mounting and chain hanging are supplied.

**ELECTRICAL:** 59 watt Octron 265MA, High Power Factor, 75 watt Slimline 430MA, High Power Factor, 110 watt or 215 watt Power Groove, Very High Output 1500MA, ETL-CBM, Class "P" approved for 118V 60 Hz operation standard. EB 75 watt Slimline only. Optional ballasts, voltages and frequencies available, see OPTIONS and consult factory.

**FINISH:** All steel components parts are completely protected against rust and discoloration after fabrication through an automated conveyorized multi-stage phosphate bonding process. Finished with an electrostatic baked white polyester thermosetting powder coating. This electronic computer controlled integrated system assures consistent 88%+ reflectance efficiency and maximum durability.

**CERTIFICATION:** The Series 2700 is U.L. and C.U.L. listed and bears the label of the I.B.E.W./AFL-CIO, Local #3. Optionally listed for damp location "DL".

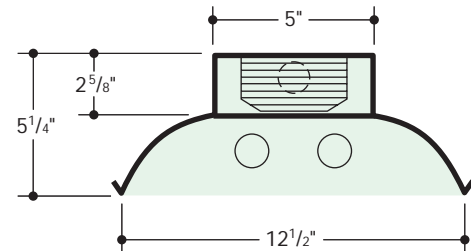

**2 Lamps**

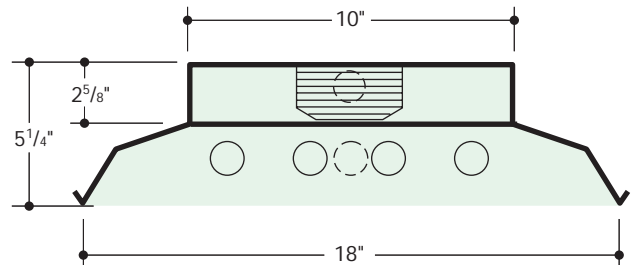

**3 and 4 Lamps**

XTRALUME® and LEGION® are registered trademarks of LEGION LIGHTING CO., INC.

## ORDERING DATA

Catalog No.	Number and Type Lamps					Nominal Dimensions	Wt.
	OCT265MA	SL-430MA	HO-1500MA	VHO-1500MA	PG-1500MA		
2700-248SL	----	2-38W-SL-T12	----	----	----	12½" x 48"	17
2700-348SL	----	3-38W-SL-T12	----	----	----	18" x 48"	33
2700-448SL	----	4-38W-SL-T12	----	----	----		38
2700-296SL	----	2-75W-SL-T12	----	----	----	12½" x 96"	31
2700-296SL EBO	2-F096-OCT-T8	----	----	----	----		31
2700-396SL	----	3-75W-SL-T12	----	----	----	18" x 96"	55
2700-396SL EBO	3-F096-OCT-T8	----	----	----	----		55
2700-496SL	----	4-75W-SL-T12	----	----	----		64
2700-496SL EBO	4-F096-OCT-T8	----	----	----	----		64
2700-296HO	----	----	2-F96-HO-T8	----	----	12½" x 96"	37
2700-396HO	----	----	3-F96-HO-T8	----	----	18" x 96"	64
2700-496HO	----	----	4-F96-HO-T8	----	----		69
2700-248VHO	----	----	----	2-110W-VHO-T12	----	12½" x 48"	24
2700-296VHO	----	----	----	2-215W-VHO-T12	----	12½" x 96"	38
2700-248PG	----	----	----	----	2-110W-PG-T17	12½" x 48"	24
2700-296PG	----	----	----	----	2-215W-PG-T17	12½" x 96"	38

## OPTIONS

Suffix "LT" after cat. no. for Cold Weather ballast.  
 Suffix "EM" after cat. no. for Emergency Battery Pack and see price list for types.  
 Suffix "DL" after cat. no. for Damp Location.  
 Suffix "WG" after cat. no. for Wire Guard.  
 Suffix "A10" after cat. no. for 10% upright slots in reflector.  
 Suffix "XTA" after cat. no. for XTRALUME® reflector standard with 85% reflectance. For 95% reflectance please specify your requirements.

## ELECTRONIC

Add Suffix after catalog number:  
 "EBT"-Electronic T12 Ballast  
 "EBO"-Electronic T8 Octron Ballast  
 "EBD"-Electronic T12 Dimming Ballast  
 "EBDO"-Electronic T8 Dimming Ballast

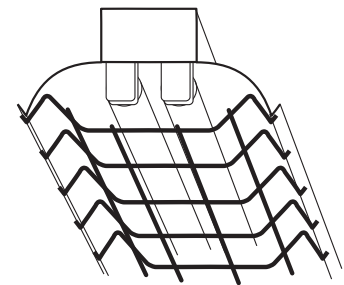

**WIRE GUARD**  
(SEE OPTIONS)

## BACK PLANS

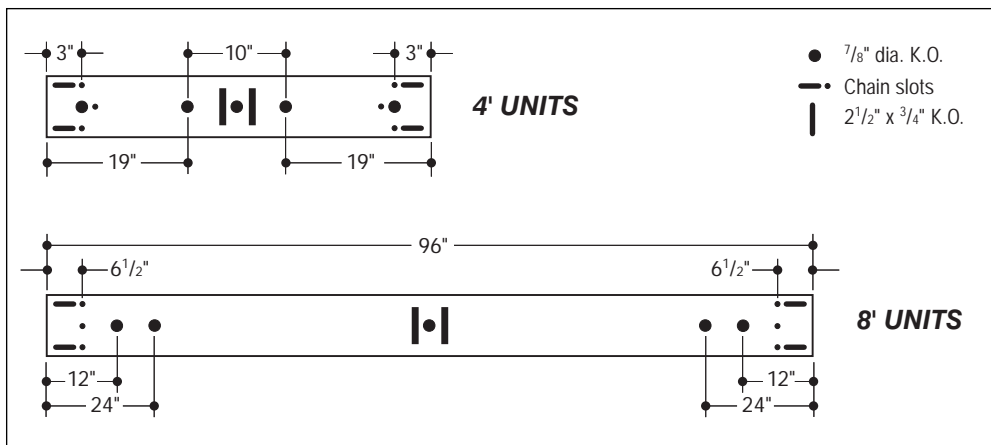

For Photometric Data see Section D - page 3A and consult factory.

Information supplied primarily for illustrative purposes, subject to change.  
 Consult factory for verification and minimum quantity orders.